

液 压 胶 管

用于高压气体管道的胶管 / G 型

<产品规格>

- 结构：内层胶管 -----具有优异的耐气体性以及耐液氨性能的合成橡胶。
加强层 -----高强度钢丝
外层胶管 -----合成纤维
- 流体：氨、氮、氢、氧和二氧化碳气体
(运输液体时，请垂询十川橡胶)
- 流体的温度范围：-40℃~+80℃
- 推荐环境温度范围：-40℃~+50℃

G-30

部件号	标称	内径 (mm)	外径 (mm)	加强层	最高使用压力 (MPa)	最小爆破压力 (MPa)	最小弯曲半径 (mm)	大约重量 (g/m)
G-30-06	6	6.3	15.1	1W	2.9	14.7	100	295
G-30-09	9	9.5	19.1	1W	2.9	14.7	130	475
G-30-12	12	12.7	22.2	1W	2.9	14.7	170	555
G-30-19	19	19.0	29.4	1W	2.9	14.7	240	770
G-30-25	25	25.4	38.0	1W	2.9	14.7	300	1,190
G-30-32	32	31.8	48.5	1W	2.9	14.7	380	1,785
G-30-38	38	38.1	54.8	1W	2.9	14.7	500	2,120
G-30-50	50	50.8	67.5	2W	2.9	14.7	630	3,195

G-150

部件号	标称	内径 (mm)	外径 (mm)	加强层	最高使用压力 (MPa)	最小爆破压力 (MPa)	最小弯曲半径 (mm)	大约重量 (g/m)
G-150-06	6	6.3	15.1	2W	14.7	58.8	100	370
G-150-09	9	9.5	19.1	2W	14.7	58.8	120	595
G-150-12	12	12.7	22.2	2W	14.7	58.8	160	695
G-150-19	19	19.0	29.4	2W	14.7	58.8	210	1,000
G-150-25	25	25.4	38.3	2W	14.7	58.8	280	1,495
G-150-32	32	31.8	49.4	4S	14.7	58.8	410	3,015
G-150-38	38	38.1	56.3	4S	14.7	58.8	500	3,665
G-150-50	50	50.8	69.4	4S	14.7	58.8	600	4,715



株式会社 十川橡胶

邮编 550-0015 日本大阪市西区南堀江 4 丁目 2 番 5 号

电话: +81-6-6538-1261 传真: +81-6-6531-3238

E-mail: eigyo@togawa.co.jp URL: <https://www.togawa.co.jp>

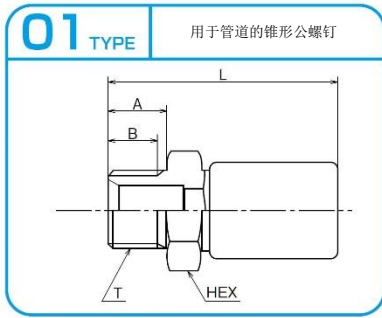

标称	T 螺纹 种类	内径 (mm)	A (mm)	B (mm)	L (mm)	HEX (mm)	部件号	胶管号
6	R 1/4	4	14	11	55	19	6-01-G	G-30·G-150
9	R 3/8	7	15	12	62	22	9-01-G	G-30·G-150
12	R 1/2	10	19	16	68	27	12-01-G	G-30·G-150
19	R 3/4	15.5	20	17	79	36	19-01-G	G-30·G-150
25	R1	21	23	20	88	41	25-01-G	G-30·G-150
32	R1 1/4	27	26	23	113	50	32-01-G	G-30
		26			135		32-01-S-Z	G-150
38	R1 1/2	33	26	23	117	60	38-01-G	G-30
		32			146		38-01-S-Z	G-150
50	R2	46	30	26	134	70	50-01-G	G-30
		42			166		50-01-S-Z	G-150

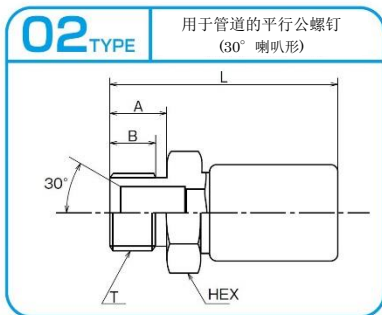

标称	T 螺纹 种类	内径 (mm)	A (mm)	B (mm)	L (mm)	HEX (mm)	部件号	胶管号
6	G 1/4	4	14	11	55	19	6-02-G	G-30·G-150
9	G 3/8	7	15	12	62	22	9-02-G	G-30·G-150
12	G 1/2	10	19	15	68	27	12-02-G	G-30·G-150
19	G 3/4	15.5	20	16	79	36	19-02-G	G-30·G-150
25	G1	21	23	18	88	41	25-02-G	G-30·G-150
32	G1 1/4	27	26	21	113	50	32-02-G	G-30
		26			135		32-02-S-Z	G-150
38	G1 1/2	33	26	21	117	60	38-02-G	G-30
		32			146		38-02-S-Z	G-150
50	G2	46	30	25	134	70	50-02-G	G-30
		42			166		50-02-S-Z	G-150

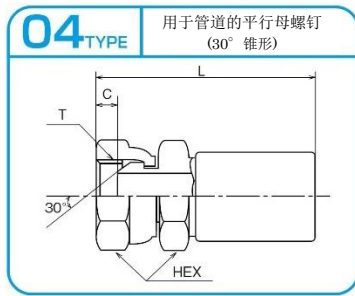

标称	T 螺纹 种类	内径 (mm)	C (mm)	L (mm)	HEX (mm)	部件号	胶管号
6	G 1/4	4	5	59	19	6-04-G	G-30-G-150
9	G 3/8	7	6	64	22	9-04-G	G-30-G-150
12	G 1/2	10	6.5	70.5	27	12-04-G	G-30-G-150
19	G 3/4	15.5	8	83.5	36	19-04-G	G-30-G-150
25	G1	21	9	92	41	25-04-G	G-30-G-150
32	G1 1/4	27	13	119	50	32-04-G	G-30
		26		138		32-04-S-Z	G-150
38	G1 1/2	33	13	124	60	38-04-G	G-30
		32		150		38-04-S-Z	G-150
50	G2	46	16	141	70	50-04-G	G-30
		42		173		50-04-S-Z	G-150

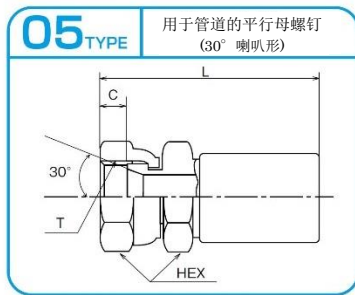

标称	T 螺纹 种类	内径 (mm)	C (mm)	L (mm)	HEX (mm)	部件号	胶管号
6	G 1/4	4	8	59	19	6-05-G	G-30-G-150
9	G 3/8	7	10	64	22	9-05-G	G-30-G-150
12	G 1/2	10	12	70.5	27	12-05-G	G-30-G-150
19	G 3/4	15.5	14	83.5	36	19-05-G	G-30-G-150
25	G1	21	14	92	41	25-05-G	G-30-G-150
32	G1 1/4	27	16	119	50	32-05-G	G-30
		26		138		32-05-S-Z	G-150
38	G1 1/2	33	16	124	60	38-05-G	G-30
		32		150		38-05-S-Z	G-150
50	G2	46	19	141	70	50-05-G	G-30
		42		173		50-05-S-Z	G-150