

HYDRAULIC HOSE

HOSE FOR HIGH PRESSURE STEAM PIPING / STW TYPE

<Specifications>

- Construction : Tube ----- Synthetic rubber excellent in heat resistance
Reinforcement ----- High tensile steel wire
Cover ----- Synthetic rubber excellent in heat and weather resistance
- Ambient temperature : -40°C to +70°C

⚠ **Caution** : According to use conditions, the hose may strikingly deteriorate and need to be replaced with a new one in a short time.

STW-150

Part No.	Nominal Size	I.D. (mm)	O.D. (mm)	Reinforcement	Max Working Pressure (MPa)	Min Burst Pressure (MPa)	Min Bend Radius (mm)	Approx. Weight (g/m)
STW-150-06	6	6.3	19.7	1W	1.0	10.0	150	415
STW-150-09	9	9.5	22.9	1W	1.0	10.0	170	530
STW-150-12	12	12.7	26.1	1W	1.0	10.0	200	605
STW-150-19	19	19.0	32.4	1W	1.0	10.0	250	845
STW-150-25	25	25.4	41.6	1W	1.0	10.0	350	1,230
STW-150-32	32	31.8	48.0	1W	1.0	10.0	400	1,535
STW-150-38	38	38.1	52.3	1W	1.0	10.0	430	1,600
STW-150-50	50	50.8	67.8	1W	1.0	10.0	550	2,415

- Max working saturated vapor temperature : +183°C

STW-250

Part No.	Nominal Size	I.D. (mm)	O.D. (mm)	Reinforcement	Max Working Pressure (MPa)	Min Burst Pressure (MPa)	Min Bend Radius (mm)	Approx. Weight (g/m)
STW-250-12	12	12.7	26.3	2W	1.7	17.2	200	690
STW-250-19	19	19.0	33.2	2W	1.7	17.2	250	1,035
STW-250-25	25	25.4	41.8	2W	1.7	17.2	350	1,405
STW-250-32	32	31.8	48.4	2W	1.7	17.2	400	1,795
STW-250-38	38	38.1	52.7	2W	1.7	17.2	430	1,900
STW-250-50	50	50.8	68.2	2W	1.7	17.2	550	2,815

- Max working saturated vapor temperature : +205°C



TOGAWA RUBBER CO., LTD.

4-2-5 MINAMI-HORIE, NISHI-KU, OSAKA, 550-0015, JAPAN.

TEL: +81-6-6538-1261 FAX: +81-6-6531-3238

E-mail: eigyo@togawa.co.jp URL: http://www.togawa.co.jp

HOSE COUPLING

Hose for high pressure steam piping / STW type

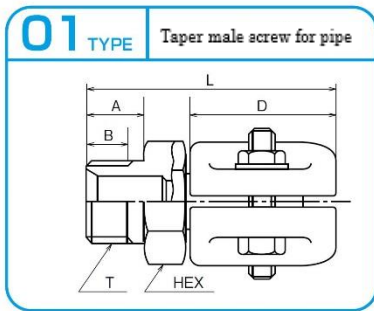

Nominal Size	T Thread	I.D. (mm)	A (mm)	B (mm)	L (mm)	D (mm)	HEX (mm)	Part No.	Hose Part No.
9	R 3/8	6	15	12	62	35	22	9-01-STW	STW-150
12	R 1/2	9	19	16	72	41	27	12-01-STW	STW-150-STW-250
19	R 3/4	15	20	17	86	50	36	19-01-STW	STW-150-STW-250
25	R1	21	23	20	95	62	41	25-01-STW	STW-150-STW-250
32	R1 1/4	27	26	23	115	75	50	32-01-STW	STW-150-STW-250
38	R1 1/2	33	26	23	120	75	60	38-01-STW	STW-150-STW-250
50	R2	45	30	26	145	90	70	50-01-STW	STW-150-STW-250

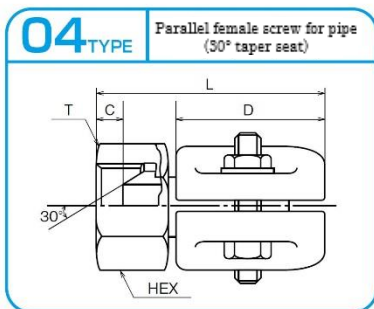

Nominal Size	T Thread	I.D. (mm)	C (mm)	L (mm)	D (mm)	HEX (mm)	Part No.	Hose Part No.
9	G 3/8	6	7.5	58	35	22	9-04-STW	STW-150
12	G 1/2	9	7.5	66	40	27	12-04-STW	STW-150-STW-250
19	G 3/4	15	9	80	50	36	19-04-STW	STW-150-STW-250
25	G1	21	9	88	60	41	25-04-STW	STW-150-STW-250
32	G1 1/4	27	12	109	75	50	32-04-STW	STW-150-STW-250
38	G1 1/2	33	12	114	75	60	38-04-STW	STW-150-STW-250
50	G2	45	13.5	130	90	70	50-04-STW	STW-150-STW-250

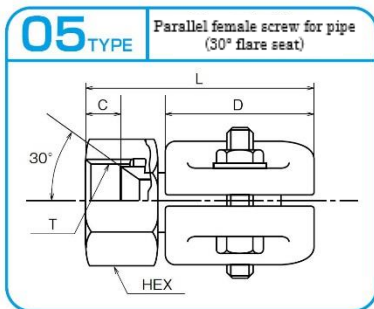

Nominal Size	T Thread	I.D. (mm)	C (mm)	L (mm)	D (mm)	HEX (mm)	Part No.	Hose Part No.
9	G 3/8	6	9.5	58	35	22	9-05-STW	STW-150
12	G 1/2	9	10.5	66	41	27	12-05-STW	STW-150-STW-250
19	G 3/4	15	14	80	50	36	19-05-STW	STW-150-STW-250
25	G1	21	14	88	62	41	25-05-STW	STW-150-STW-250
32	G1 1/4	27	16	109	75	50	32-05-STW	STW-150-STW-250
38	G1 1/2	33	16	114	75	60	38-05-STW	STW-150-STW-250
50	G2	45	19.5	130	90	70	50-05-STW	STW-150-STW-250